



SafeToGo[®]

Customisation guide



The background of the slide is a close-up, slightly blurred image of a computer keyboard. Overlaid on the keyboard is a grid of numerous USB drives. Each drive is white with a red shield-shaped logo on the top half and a black cap on the bottom half. The drives are arranged in rows and columns, creating a sense of depth and repetition. The text is centered over this background.

Multi-award winning Cardwave Services works with customers of all sizes across the world, providing specialist expertise to organisations who need to secure and distribute their data on removable and embedded media.

We can provide you with a customisation service for SafeToGo[®] that includes:

- 1) Company logos
- 2) Serialisation
- 3) Packaging
- 4) Data preload

Index

USB dimensions	3
Colour options	4
Printing and engraving	4
Packaging	6
Data preload	6
Logo specifications	7-8
Process	10

Please contact Pete, Lisa or Lucy in our Customer Services team to discuss further.

Cardwave Services Limited, 6c Hopton Industrial Estate, Devizes, Wiltshire SN10 2EU.
Tel: +44 (0) 1380 738395 Email: sales@cardwave.com

We take time to understand your requirements to provide you with the right solution

SafeToGo[®] hardware encrypted USB dimensions

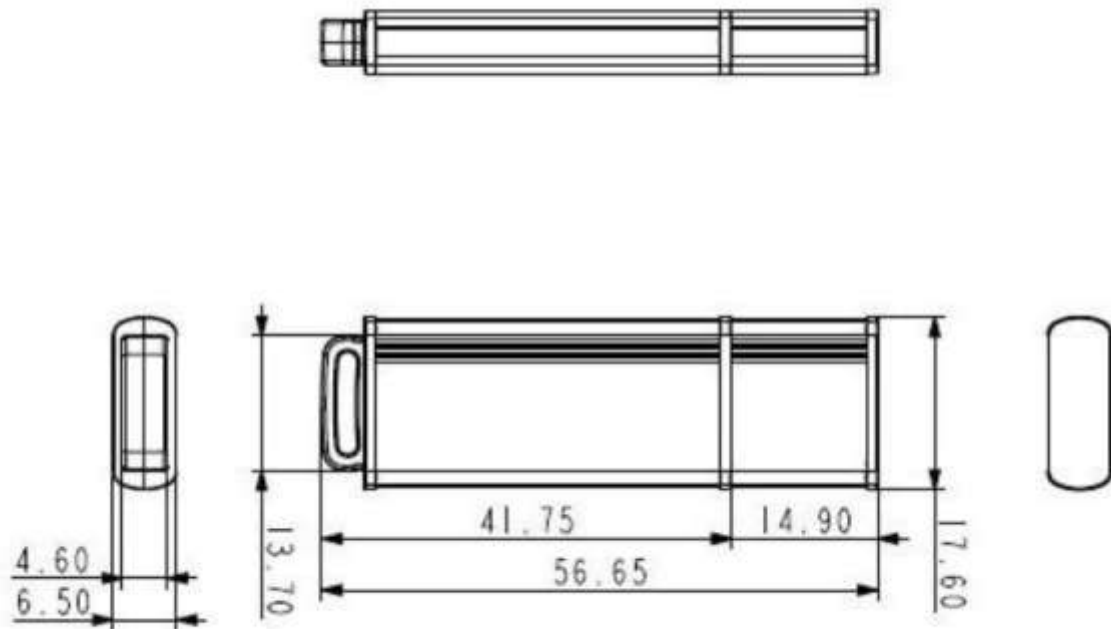

For a full specification of SafeToGo[®] please refer to our website at www.safetogousb.com



Your USB housing colour choices

Black is the standard casing colour. We also offer a silver version of the drive (M0Q3K). Custom colour housings are available for orders over 5,000.



Printing options

2 colour printing example

Laser etched example



**We care as much
about your
customer
experience
as you do**

**Outstanding
customer
service is our
goal and of
utmost importance
to us**

Packaging options

Our standard packaging is a matchbox style box with a printed sleeve. We are also happy to ship in trays of 100.

Lanyards are not included as standard but can be added to an order if required.



Data preload

SafeToGo® is a hardware encrypted USB drive that requires a user to create their own user name and password. It is however possible to preload some files but this requires Cardwave to create temporary user names and passwords. Passwords can be changed when the drive is allocated to a user.

User screen

Please note that the SafeToGo® user screen cannot be customised.

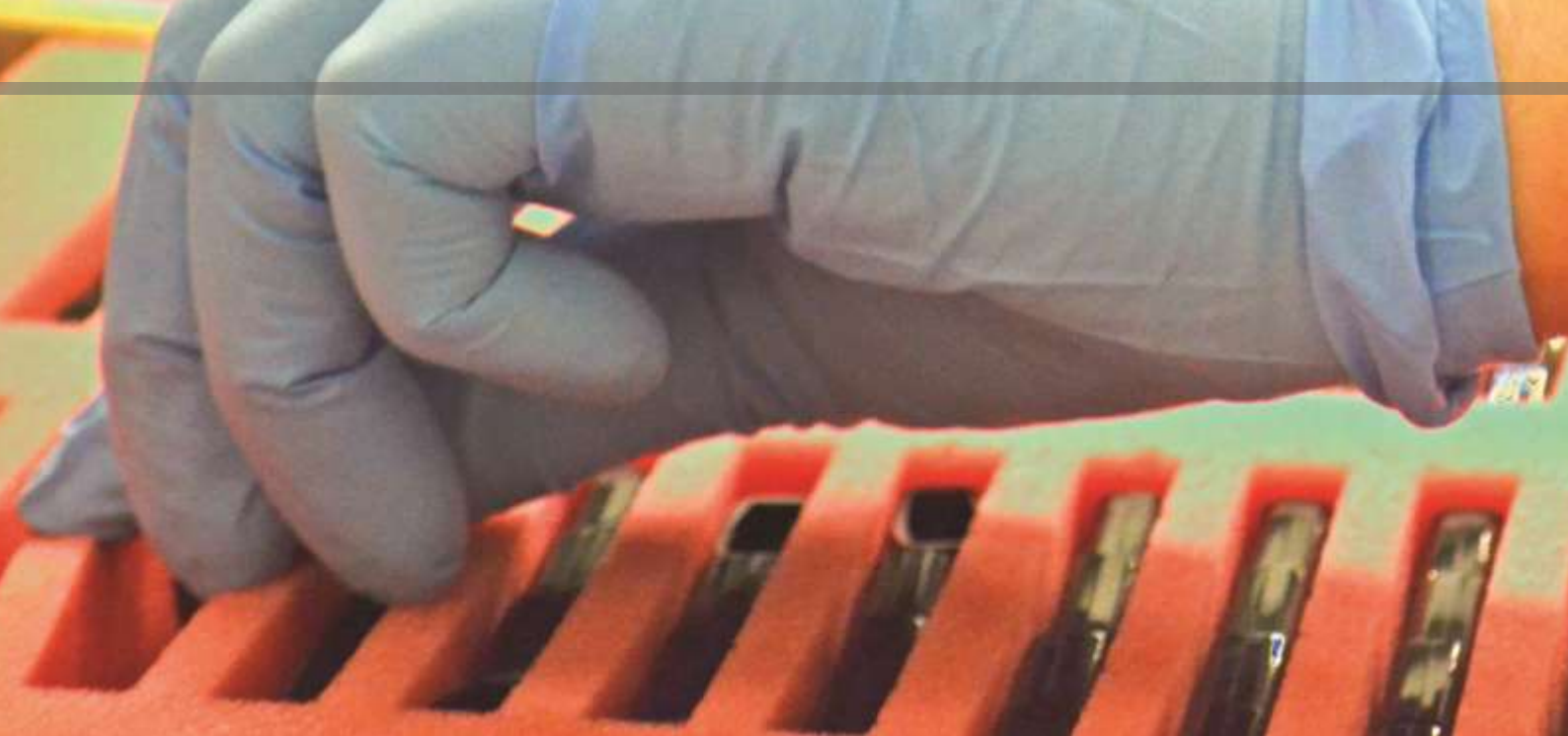

Logo specification for USB printing

Area available for logo placement

- 32mm wide x 8mm deep.



Number of colours

- A maximum of four colours can be printed onto one side of the USB.
- Alternatively the USB can be laser etched.
- Logos provided must be high resolution and either CMYK or PANTONE® - please refer to page 8 for full details.

Disclaimer: The quality of the logo and colours printed is dependent on the file we have been supplied with, as well as the ability of the print process.



Logo format

Please provide us with one of the following file types:

Programme	File types	Requirements
Photoshop	PSD, EPS, TIFF, JPG	Pixel-based images should be CMYK and have a resolution of at least 300dpi. Single colour images should have a resolution of 1200dpi. Request unflattened artwork wherever possible, with all used fonts supplied.
Illustrator	AI, EPS	Please convert all fonts to outlines. All images must be supplied in vector format where possible. Any PANTONE® colours to be used to be clearly indicated.
QuarkXPress	QXD	Please supply any linked graphics and fonts used. All linked images to be CMYK and 300dpi or more.
InDesign	IND	Please supply any linked graphics and fonts used. All linked images to be CMYK and 300dpi or more.
Adobe Acrobat	PDF	PDF's to be output as 'Press Quality'. All images used to be CMYK and 300dpi or more. It is essential that FONTS are compressed (e.g. with Winzip or Stuffit) to ensure they do not corrupt when sending.

Artwork supply email address: info@cardwave.com



With production facilities in the UK and US, Cardwave can work with you to ensure the right product/s are delivered to specification and to the right timescales, giving you the best possible end user experience

Process for requesting a customised SafeToGo[®]

Quotations

We will email you a quote, once we have received your logo we will provide you with a digital mock-up showing how your logo looks on the SafeToGo[®] USB. A Customer Account Manager will be assigned to you to guide you through this process.

Note: Sending us your logo in a high resolution or vector file format will speed up the process. Please refer to page 8.

Production and customisation

Our Production team will process your order on receipt of your acceptance and authorisation of the digital proof.

Quality control

Once the USBs have been printed or engraved, your order is passed to our ISO accredited Quality Control team.

Shipping and accounts

Once the Quality Control team has completed their checks of every item of your order, our Packaging team carefully prepares your order for shipment. You will be provided with a delivery tracking number after the goods have been shipped with your preferred shipping distributor.

Please contact Pete, Lisa or Lucy in our Customer Services team to discuss further.

Cardwave Services Limited, 6c Hopton Industrial Estate, Devizes, Wiltshire SN10 2EU.
Tel: +44 (0) 1380 738395 Email: sales@cardwave.com

Connect with us on social media:

